

HOT CONDENSATE COOLERS HCC

DESCRIPTION

The HCC is a cooling device that allows the mixing of hot condensate with a lower temperature condensate, avoiding hammering.

Condensate discharge from higher pressure lines (drip points, for instance) are often connected to low pressure condensate lines, with lower temperature. This sudden pressure drop will convert the sensible heat difference between the two fluid conditions into latent heat, generating flash steam.

Flash steam has a much bigger volume than condensate and, when mixed with the cold condensate, it will cool suddenly, imploding and causing hammering (noise and vibration).

The HCC avoids this phenomenon, since it slowly cools down the hot condensate which circulates inside a coil, surrounded by cold condensate which circulates according to the thermo-siphon physical laws.

MAIN FEATURES

Eliminates hammering.

Corrosion-resistant internal coil.

OPTIONS: Larger flow rates.
 Special tailored designs.

USE: Condensate discharge downstream of steam traps.

AVAILABLE

MODELS: HCC3 – up to 300 kg/h.
 HCC10 – up to 500 kg/h.

CONNECTIONS: Flanged EN 1092-1 PN16 and PN40.
 Flanged ANSI B16.5 Class 150 lb or 300 lb.
 Others on request.

CONSTRUCTION: Carbon steel or stainless steel on request.

INSTALLATION: Vertical installation.
 Hot condensate angle inlet and vertical outlet.
 Cold condensate bottom inlet and vertical outlet.



BODY LIMITING CONDITIONS *								
Rating	Pressure (bar)	Temperature (°C)	Rating	Pressure (bar)	Temperature (°C)	Rating	Pressure (bar)	Temperature (°C)
PN16	16	50	ANSI 150 lb	16	50	PN40 / ANSI 300 lb	40	50
	14	100		16	100		40	100
	13 **	195		13 **	195		32 **	240
	12	250		12	250		30	300

* Rating according to EN 1092-1:2018. Other conditions on request; ** PMO – Maximum operating pressure for saturated steam.
Minimum operating temperature: -10 °C; Design code: AD-Merkblatt.

DIMENSIONS

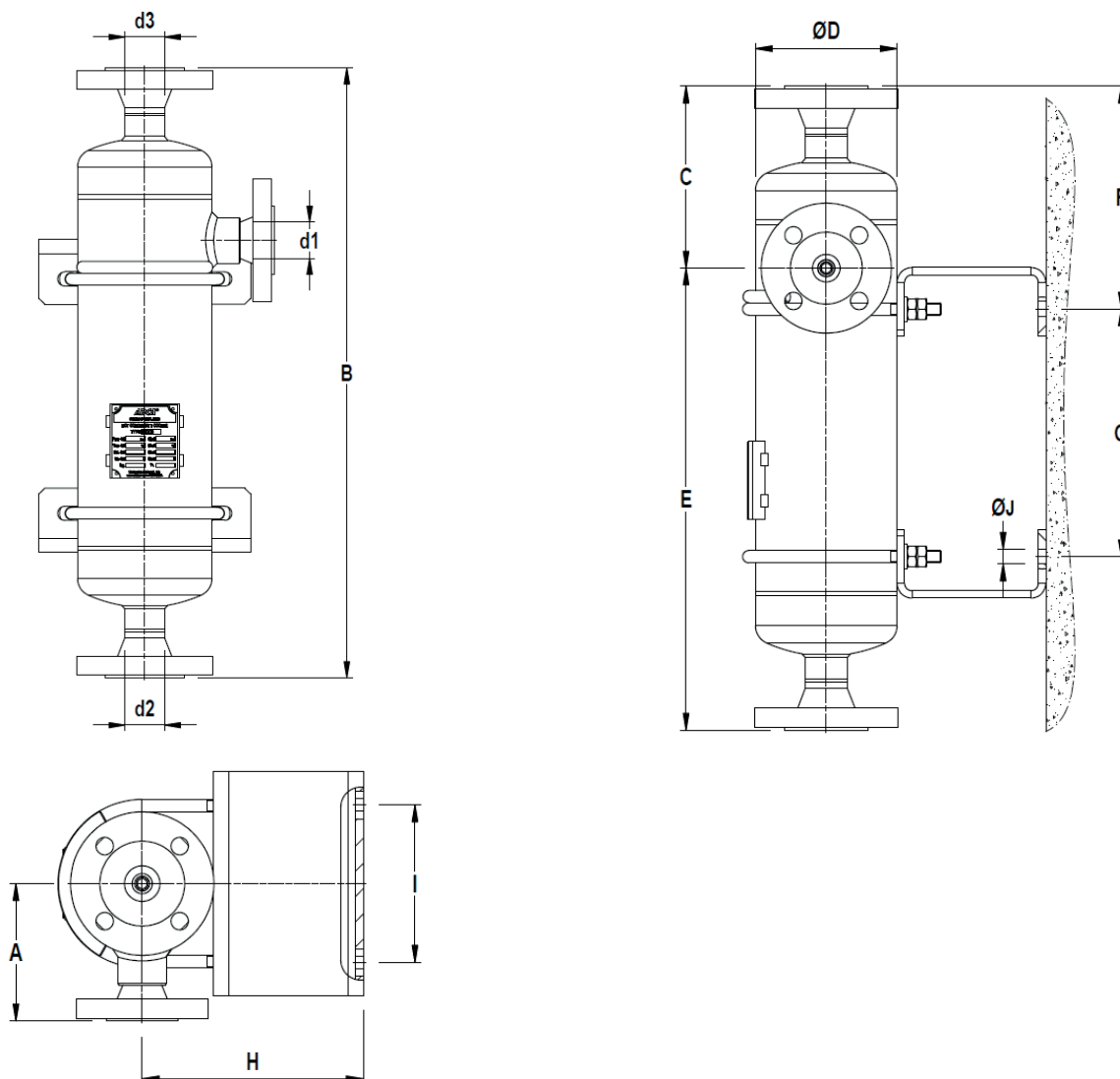

APPROXIMATE DIMENSIONS (mm) *

MODEL	SIZE	A	B	C	D	E	F	G	H	I	J	d1	d2	d3	WEIGHT (kg)
HCC3-20	DN 20 x 25	110	530	155	115	375	185	200	177	126	12	20	25	25	13,8
HCC3-25	DN 25 x 25	110	530	155	115	375	185	200	177	126	12	25	25	25	15,5
HCC10-32	DN 32 x 50	190	715	227,5	273	487,5	266	223	257	286	14	32	50	50	62,8
HCC10-40	DN 40 x 50	190	715	227,5	273	487,5	266	223	257	286	14	40	50	50	63,1

* Values refer to EN1092-1 flanged version. For certified values and ANSI dimensions, consult manufacturer.

MATERIALS

DESIGNATION	HCC/S	HCC/SS
Tube coil	AISI 316L / 1.4404	AISI 316L / 1.4404
Heads and shell	P265GH / 1.0425 P235GH / 1.0305	AISI 316 / 1.4401 AISI 316L / 1.4404
EN flanges	P250GH / 1.0460	AISI 316 / 1.4401
ANSI flanges	ASTM A105 / 1.0432	AISI 316 / 1.4401
Sockets	ASTM A105 / 1.0432	AISI 316 / 1.4401
Supports	S235JR / 1.0038	AISI 304 / 1.4301

EN 10204 3.1 certificate available on request.

TYPICAL INSTALLATION

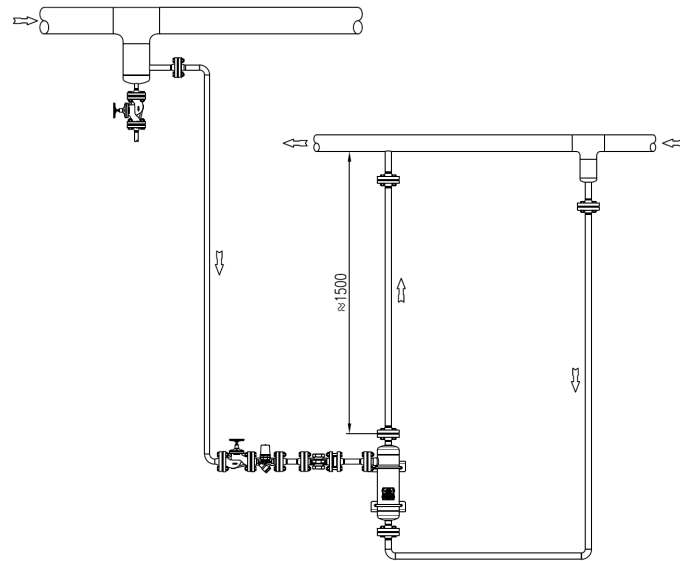

OPERATION

The steam trap hot condensate discharge from the steam line is connected to the top of the HCC coil (horizontal connection) which, in turn, is surrounded by cold condensate (Fig. 1), thus beginning to be cooled down while flowing to the top outlet (Fig.2), where it finally mixes with the colder condensate (Fig. 3). Flash steam bubbles that are formed during the process decrease, until they completely disappear, before the mentioned mixing process.

The cold condensate is connected to the bottom of the HCC (Fig.1) and, in contact with the hot coil, is warmed (Fig.2), starting its natural circulation process by thermosiphon (Fig. 3).

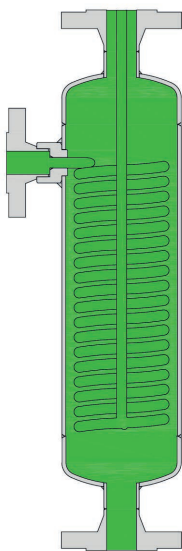

Fig. 1 - Cold system

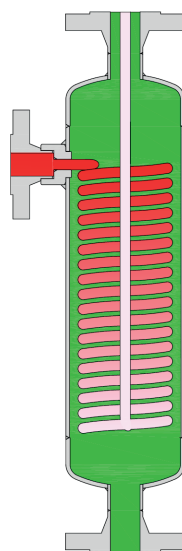

Fig. 2 - Hot condensate arrival

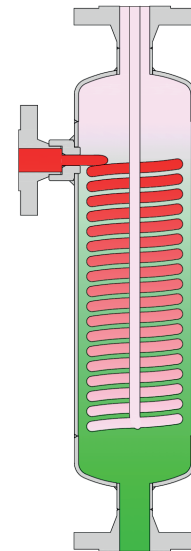

Fig. 3 - Thermosiphon process

Other applications: The HCC can be specifically designed for other applications and different flow rates, such as: Small heat exchangers and steam heaters in general; Preheating of cold make up water to a condensate vessel or deaerator; Equalizing temperature of boiler feed tanks, etc.